



NUMBER: 07-005-02

GROUP: Cooling

DATE: Dec. 16, 2002

This bulletin is supplied as technical information only and is not an authorization for repair. No part of this publication may be reproduced, stored in a retrieval system, or transmitted, in any form or by any means, electronic, mechanical, photocopying, or otherwise, without written permission of DaimlerChrysler Corporation.

THIS BULLETIN IS BEING PROVIDED IN ADVANCE. DO NOT ORDER PARTS OR PERFORM ANY ACTIONS RELATED TO THIS BULLETIN UNTIL JAN. 20, 2003.

SUBJECT:

Newly Released Solenoid For DTC P1499 - Hydraulic Fan Solenoid Circuit Fault

OVERVIEW:

This bulletin involves the replacement of the hydraulic fan solenoid instead of the complete cooling fan module.

MODELS:

- 2001 - 2004 (WJ) Grand Cherokee
- 2001 - 2004 (WG) Grand Cherokee (International Markets)

NOTE: THIS BULLETIN APPLIES TO VEHICLES EQUIPPED WITH A HYDRAULIC COOLING SYSTEM (SALES CODE NMH).

SYMPTOM/CONDITION:

The customer may experience a MIL illumination due to DTC P1499 - Hydraulic Fan Solenoid Circuit. The MIL illumination may occur intermittently.

DIAGNOSIS:

1. Proceed with this bulletin only if the cause of the MIL illumination is due to DTC P1499 - Hydraulic Fan Solenoid Circuit Fault.
2. Refer to the 2002 or later Jeep Grand Cherokee – Powertrain Diagnostic Procedures Manual to properly diagnose DTC P1499.
3. If the diagnostic procedures determine that the hydraulic fan solenoid is at fault, then perform the Repair Procedure.

NOTE: THE HYDRAULIC FAN SOLENOID LISTED BELOW HAS BEEN RELEASED AS A SEPARATE ITEM. THE COMPLETE HYDRAULIC FAN MODULE NO LONGER REQUIRES REPLACEMENT WHEN ONLY THE SOLENOID IS FOUND TO BE AT FAULT.

PARTS REQUIRED:

Qty.	Part No.	Description
1	05102210AA	Solenoid, Hydraulic Fan

EQUIPMENT REQUIRED:

CH6000	Scan Tool (DRB III®)
CH7000/7001	J1962 Cable

REPAIR PROCEDURE:

1. With the engine off, disconnect the negative battery cable from the negative battery terminal.
2. Raise the vehicle on a suitable lift.
3. Clean the immediate area around the hydraulic fan solenoid of any debris.
4. Disconnect the electrical harness from the hydraulic fan solenoid (Fig. 1).

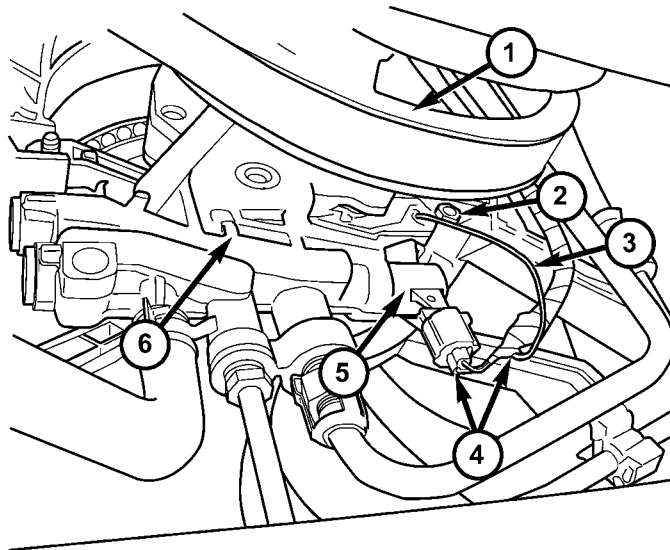

8107040f

Fig. 1 HYDRAULIC FAN MODULE / SOLENOID

- 1 - Crankshaft Pulley
- 2 - Ground Strap Retention Nut
- 3 - Ground Strap (Must Be Connected To Fan Module)
- 4 - Hydraulic Fan Solenoid Electrical Harness/Connector
- 5 - Hydraulic Fan Solenoid (Serviceable Separately)
- 6 - Hydraulic Fan Module

5. Have the new hydraulic fan solenoid ready for installation. Make certain that the two o-rings are in place. Notice that the armature of the solenoid can rotate within the body of the solenoid (coil). A T40 torx bit is used for removal and installation (Fig. 2).

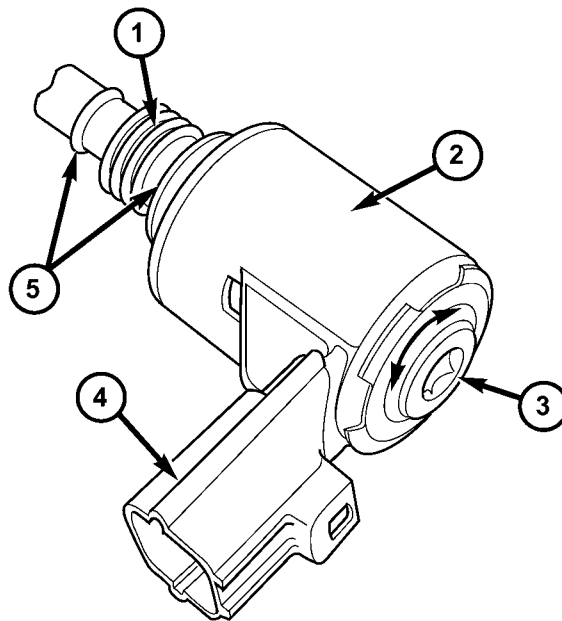

8107040e

Fig. 2 HYDRAULIC FAN SOLENOID

- 1 - Solenoid Armature (rotates within solenoid coil/housing)
 - 2 - Solenoid Coil / Housing
 - 3 - T40 Torx Fitting
 - 4 - Solenoid Electrical Connector
 - 5 - Two Sealing O-Rings on Armature
-

NOTE: IF THE SOLENOID REMOVAL AND REPLACEMENT STEPS ARE PERFORMED QUICKLY, THEN ONLY A VERY SMALL AMOUNT OF STEERING FLUID WILL DRIP FROM THE FAN MODULE HYDRAULIC FAN SOLENOID OPENING. THE SMALL AMOUNT OF LEAKAGE SHOULD NOT REQUIRE PRIOR FLUID REMOVAL FROM THE POWER STEERING RESERVOIR.

- 6. Hold the connector of the solenoid to prevent the solenoid body from turning, and remove the hydraulic fan solenoid from the hydraulic fan module.
- 7. Immediately install the new hydraulic fan solenoid. Tighten the solenoid to 16.2 Nm (12 ft. lbs.).
- 8. Connect the electrical harness to the hydraulic fan solenoid.

NOTE: IF FOR ANY REASON DURING THE REPAIR PROCEDURE THE ELECTRICAL GROUND WIRE IS REMOVED FROM THE HYDRAULIC FAN MODULE ASSEMBLY, THEN RECONNECT THE GROUND WIRE AND TIGHTEN THE RETENTION NUT TO 10 NM (7.4 FT. LBS.). FAILURE TO ENSURE THE GROUND STRAP IS PROPERLY CONNECTED COULD RESULT IN ELECTROSTATIC DISCHARGE THAT MAY DAMAGE THE PCM.

- 9. Lower the vehicle.
- 10. Connect the negative battery cable to the battery negative terminal.
- 11. Verify the fluid level in the power steering reservoir. Top off the fluid level as necessary.

POLICY:

Reimbursable within the provisions of the warranty.

TIME ALLOWANCE:

Labor Operation No:	Description	Amount
08-30-18-91	Replace Hydraulic Fan Solenoid	0.4 Hrs.

FAILURE CODE:

ML	Check Engine / Service Engine Soon
----	------------------------------------